



3 GHz N N/O S.P.10T. SWITCH

OPTIONS : /SUPP.DIODES

R F CHARACTERISTICS

NUMBER OF WAYS : 10
FREQUENCY RANGE : 0 - 3 GHz
IMPEDANCE : 50 Ohms

FREQUENCY (GHz)	0 - 3
V.S.W.R <=	1.30
INSERT. LOSS <=	0.30 dB
ISOLATION >=	80 dB
AVER. POWER (*)	400 W

ELECTRICAL CHARACTERISTICS

ACTUATOR : NORMALLY OPEN
NOMINAL CURRENT AT 25° C (±10%) : 250 mA
ACTUATOR VOLTAGE (Vcc) : 12V (10.2 to 13V) / POSITIVE COMMON
TERMINALS : solder pins (250 deg.C max./30 sec.)

MECHANICAL CHARACTERISTICS

CONNECTORS : N female per MIL-C 39012
LIFE : 2.000.000 cycles per position
SWITCHING TIME (nominal voltage;25° C) : < 15 ms
CONSTRUCTION : splashproof
WEIGHT : < 850 g

ENVIRONMENTAL CHARACTERISTICS

OPERATING TEMPERATURE RANGE (°C) : -40 , +85
STORAGE TEMPERATURE RANGE (°C) : -55 , +85

(* : average power at 25° C per RF path)

4112-9212 This information is given as an indication. In the continual goal to improve our products, we reserve the right to make any modifications judged necessary

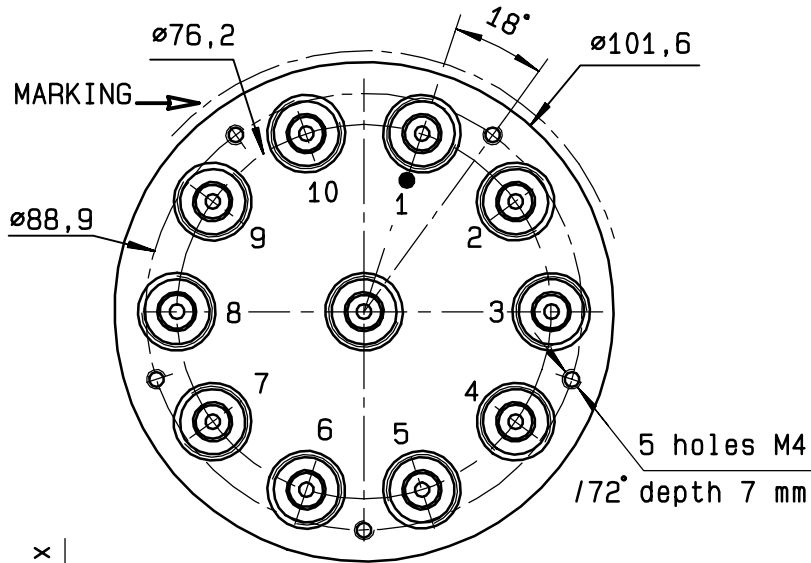

Voltage	RF continuity
+C -1	IN ↔ 1
+C -2	IN ↔ 2
+C -3	IN ↔ 3
+C -4	IN ↔ 4
+C -5	IN ↔ 5
+C -6	IN ↔ 6
+C -7	IN ↔ 7
+C -8	IN ↔ 8
+C -9	IN ↔ 9
+C -10	IN ↔ 10

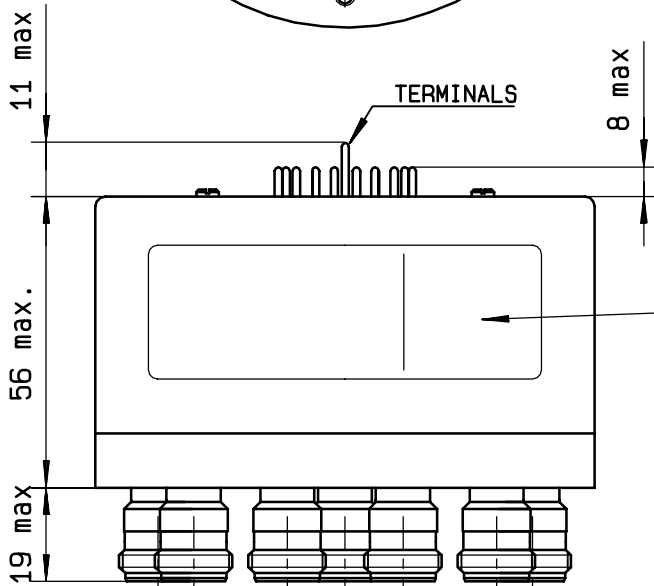

MARKING TOP VIEW (TERMINALS)

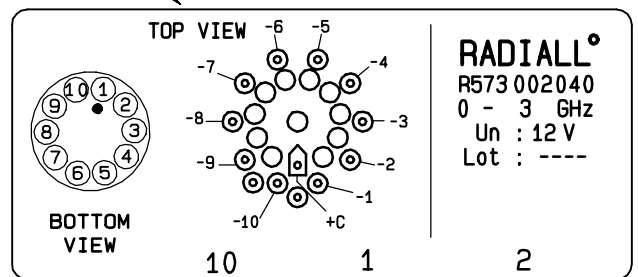

SCHEMATIC DIAGRAM

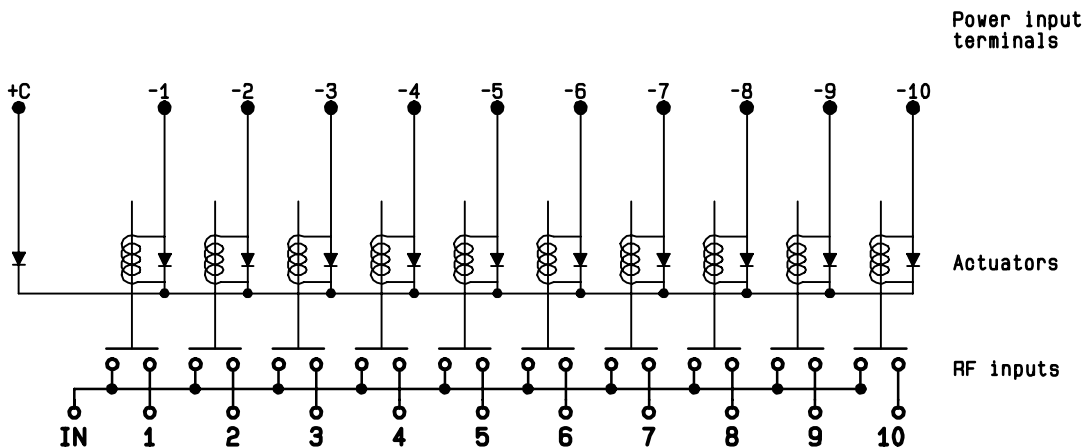

4113-9212 This information is given as an indication. In the continual goal to improve our products, we reserve the right to make any modifications judged necessary